

**Kayıklı Dişlisiz Sistem**  
*Belt Gearless System*



SESSİZ • KONFORLU • DAYANIKLI  
QUIET • COMFORTABLE • DURABLE

## Kayıklı Dişlisiz Sistem Belt Gearless System



### SMT 140BC 10/15/20

AKAR® – BELTSYS® Kayıklı Dişlisiz Sistem, SMT Serisi dişlisiz tahrik motoru, tahrik kasnağı, özel sertifikalı kayış, kayış tutucuları, kayış ömrü sayıcısı ve palanga kasnaklarından oluşur. AKAR® – BELTSYS® Kayıklı Dişlisiz Sistem, faydalı modeli alınmış olup Liftinstituut tarafından CE sistem onay belgelidir.

AKAR® – BELTSYS® Belt Gearless System consists of SMT Series gearless traction motor, traction shave, polyurethane (PU) coated steel ropes (belts), belt clamps, belt lifetime counter and deflection pulleys.

The integrated system has been CE certificated by Liftinstituut and also utility model certification has been issued.

#### SMT 140BC'NİN AVANTAJLARI

2:1 askı sistemlerinde 1000kg taşıma kapasitesine ulaşabilmektedir.

- Daha küçük tahrik kasnağı çapında daha yüksek beyan yükü taşınmasına imkan verir.
- Poliüretan kaplı çelik teller korozyondan korunmuştur.
- Özel sertifikalı kayışın ömrü çelik halata göre daha uzundur.
- Eşdeğer dişlisiz sistemlere göre daha az enerji harcar.
- Daha düşük güçlü sürücü seçilmesine olanak sağlar.
- Sessiz bir seyir ve yüksek seyir konforu sağlar.

AKAR® Elektromanyetik Fren:

- EN 81-20 ve EN 81-50 Standartlarına uygundur.

Fren Voltajı: 198V DC

Kutup Sayısı: 16

Motor Gerilimi: 360V (Diğerleri Opsiyonel)

Frekans: 50Hz

#### ADVANTAGES OF SMT 140BC

Max. payload of 1000kg for 2:1 suspension.

- Enables higher payload capacity with smaller traction sheave diameter.
- Polyurethane coated steel ropes are protected against corrosion.
- Belt has longer lifecycle than standard steel ropes.
- Lower energy consumption in comparison with equivalent gearless systems.
- Enables using less powerful inverters.
- Provides a quiet travel and high level of travel comfort.

AKAR® Electromagnetic Brake:

- Our brakes fulfill EN 81-20 and EN 81-50 Standards.

Brake Voltage: 198V DC

No of Poles: 16

Motor Voltage: 360V (Others Optional)

Frequency: 50Hz

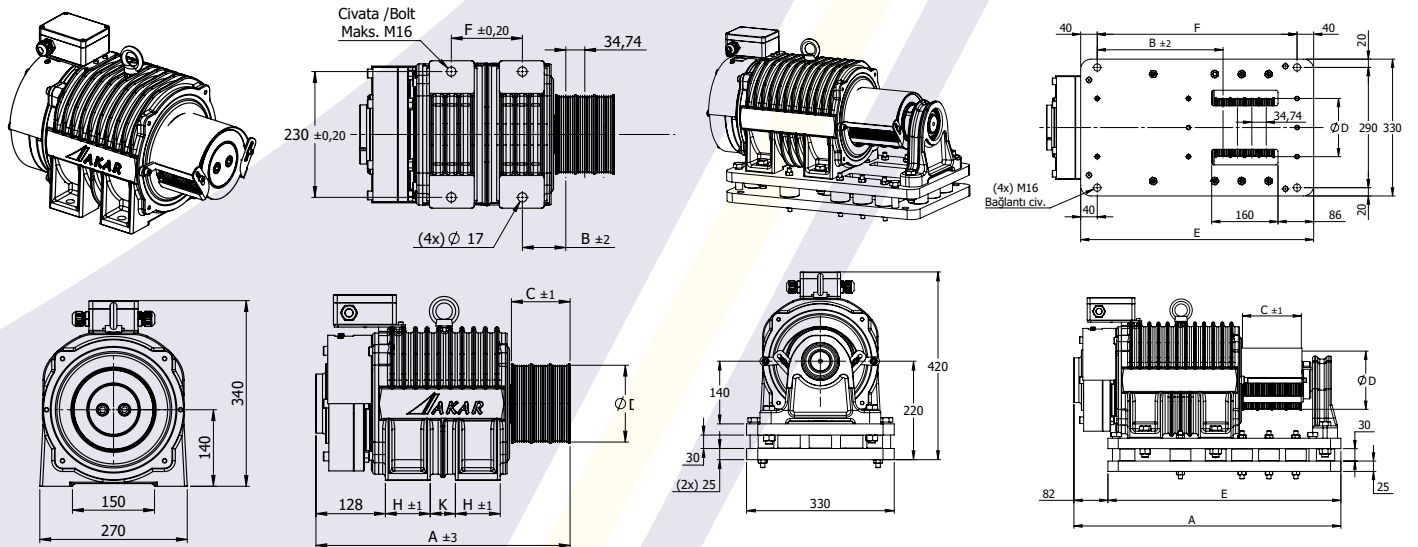

Maksimum Statik Yük  
Maximum Static Load

Yan Ayaksız  
Without Support Bearing  
2000 kg

Yan Ayaklı\*  
With Support Bearing\*  
2500kg

Motor Tipi Motor Type	Taşıma Kapasitesi Load [kg]	Kabin Hızı Car Speed [m/sn]	Kasnak Çapı Pulley Dia	Kayış Adedi No. of Belts	Motor Gücü Motor Power [Kw]	Yük Akımı ** Load Current ** [A]	Askı Suspension	Seyir Mesfesi Travel Height [m]
SMT 140 BC - 10	320	1.00	Ø120	3 #	5.7	5.5	2:1	24
SMT 140 BC - 10	320	1.60	Ø120	3 #	9.1	8		
SMT 140 BC - 10	400	1.00	Ø120	3 #	5.7	6.5		
SMT 140 BC - 10	400	1.60	Ø120	3 #	9.1	10		
SMT 140 BC - 10	450	1.00	Ø120	3 #	5.7	8		
SMT 140 BC - 10	450	1.60	Ø120	3 #	9.1	11.5		
SMT 140 BC - 10	630	1.00	Ø120	3 #	5.7	10		
SMT 140 BC - 15	630	1.60	Ø120	4 #	12.8	15		
SMT 140 BC - 15	800	1.00	Ø120	4 #	8	12.5		
SMT 140 BC - 15	800	1.60	Ø120	5 #	12.8	19		
SMT 140 BC - 20	1000	1.00	Ø120	5 #	10.7	16		
SMT 140 BC - 20	1000	1.60	Ø120	5 #	17.1	23.5		
SMT 140 BC - 10	320	1.00	Ø140	3 #	4.9	6		
SMT 140 BC - 10	320	1.60	Ø140	3 #	7.8	9		
SMT 140 BC - 10	400	1.00	Ø140	3 #	4.9	7		
SMT 140 BC - 10	400	1.60	Ø140	3 #	7.8	10.5		
SMT 140 BC - 10	450	1.00	Ø140	3 #	4.9	8		
SMT 140 BC - 10	450	1.60	Ø140	3 #	7.8	12.5		
SMT 140 BC - 10	630	1.00	Ø140	3 #	4.9	10		
SMT 140 BC - 15	630	1.60	Ø140	4 #	11	16		
SMT 140 BC - 15	800	1.00	Ø140	4 #	6.9	12.5		
SMT 140 BC - 15	800	1.60	Ø140	4 #	11	19.5		
SMT 140 BC - 20	1000	1.00	Ø140	5 #	9.1	15		
SMT 140 BC - 20	1000	1.60	Ø140	5 #	14.6	23.5		
SMT 140 BC - 10	320	1.00	Ø160	3 #	4.3	6		
SMT 140 BC - 10	320	1.60	Ø160	3 #	6.8	9		
SMT 140 BC - 10	400	1.00	Ø160	3 #	4.3	7		
SMT 140 BC - 10	400	1.60	Ø160	3 #	6.8	10.5		
SMT 140 BC - 10	450	1.00	Ø160	3 #	4.3	8		
SMT 140 BC - 10	450	1.60	Ø160	3 #	6.8	12.5		
SMT 140 BC - 10	630	1.00	Ø160	3 #	4.3	10		
SMT 140 BC - 15	630	1.60	Ø160	4 #	9.6	16		
SMT 140 BC - 15	800	1.00	Ø160	4 #	6	13.5		
SMT 140 BC - 15	800	1.60	Ø160	4 #	9.6	20		
SMT 140 BC - 20	1000	1.00	Ø160	5 #	8	16		
SMT 140 BC - 20	1000	1.60	Ø160	5 #	12.8	23.5		

\* Kayış sayısı 4 ve 5 olan sistemler yan yataklıdır.

\*\*Yük akımları (I) 24 metre seyir mesafesine göre hesaplanmıştır.

#Özel sertifikalı kayış.

- Teknik konularda sorularınız için: [teknik@akarasansor.com](mailto:teknik@akarasansor.com)

\*Our motors have support bearing for the systems with 4 and 5 belts.

\*\*Load currents (I) are calculated based on 24 meters travel height.

#Specially certificated belt.

-For technical queries: [engineering@akarasansor.com](mailto:engineering@akarasansor.com)

Motor Tipi Motor Type	Kasnak Çapı - Pulley Dia. - No. of Belts	A	B	C	ØD	E	F	G	H	K	Ağırlık Weight [kg]
		[mm]	[mm]	[mm]	[mm]	[mm]	[mm]	[mm]	[mm]	[mm]	
SMT 140BC-10	Ø120/140/160 - 3 #	467	80.5	107	120/140/160	-	130	-	82	46	115
SMT 140BC-10	Ø120/140/160 - 4 #	586	85.5	142	120/140/160	458	-	257	-	-	115
SMT 140BC-10	Ø120/140/160 - 5 #	611	80.5	176	120/140/160	483	-	282	-	-	115
SMT 140BC-15	Ø120/140/160 - 3 #	517	85.5	107	120/140/160	-	170	-	84	86	130
SMT 140BC-15	Ø120/140/160 - 4 #	635	85.5	142	120/140/160	505	-	262	-	-	130
SMT 140BC-15	Ø120/140/160 - 5 #	660	85.5	176	120/140/160	530	-	287	-	-	130
SMT 140BC-20	Ø120/140/160 - 3 #	567	100.5	107	120/140/160	-	200	-	93.5	103	150
SMT 140BC-20	Ø120/140/160 - 4 #	685	100.5	142	120/140/160	553	-	277	-	-	150
SMT 140BC-20	Ø120/140/160 - 5 #	710	100.5	176	120/140/160	578	-	302	-	-	150

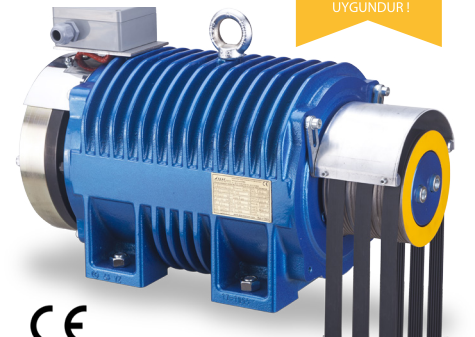

CE  
0400

EN 81-20  
EN 81-50

STANDARTLARINA  
UYGUNDUR!

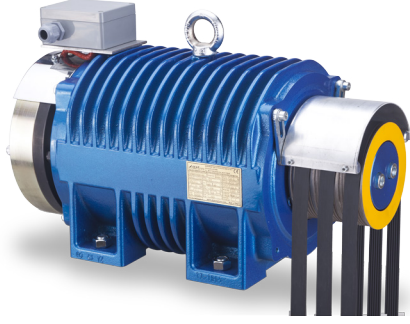

Kayış Ömrü Sayıcısı  
Belt Lifetime Counter

SMT Serisi Dişlisiz  
Tahrik Motoru ve  
Tahrik Kasnağı  
SMT Series Traction  
Motor and  
Traction Sheave

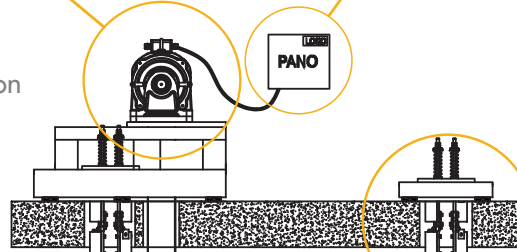

PANO



Özel Sertifikalı Kayış  
Polyurethan(PU) Coated  
Steel Ropes (Belts)



Kayış Tutucuları  
Belt Clamps

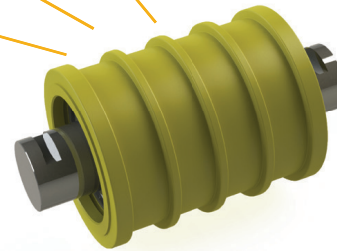
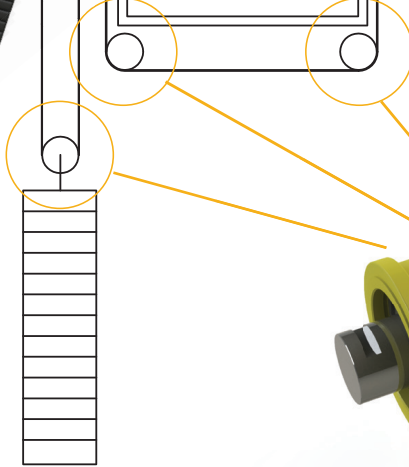

Palanga Kasnağı  
Deflection Pulleys